

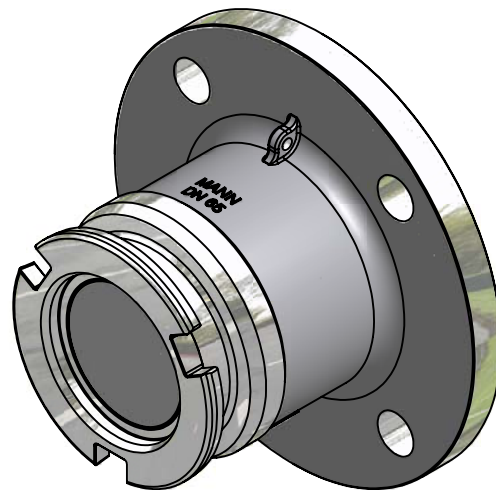

Notice: This drawing contains proprietary information and shall not be used or reproduced or its contents disclosed in whole or in part, without the prior written consent of the Mann Technik AB

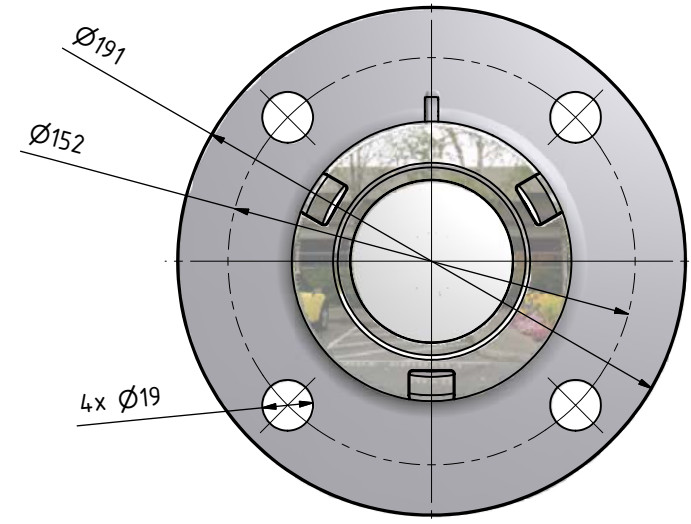
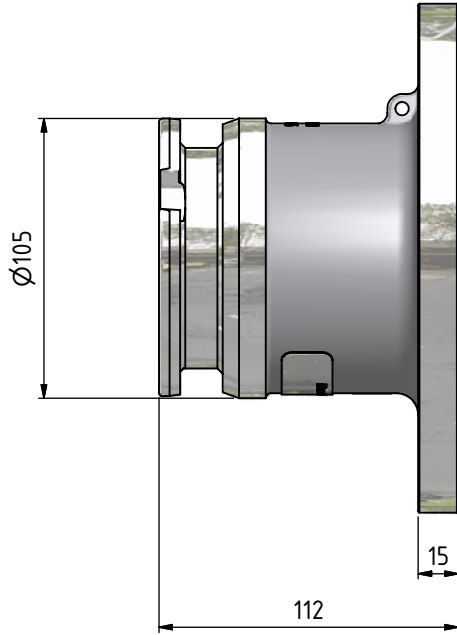

Dimensions are in metric.

Detail No:		Material		Ytbeh./Treatment	
		Designed/drawn by	Scale:	Dimension with no tolerances acc to Machined SS-ISO 2768-1 medium Weld Forge SS-ISO 2768-1 coarse Surface roughness ISO 1302 Form & position tol SS ISO 1101	
		Checked	1:2		
		Approved	Date		
		P. Nyberg			
		G. Kopplin	2007-12-11		
		T. Mann			
2 1/2" Tank Unit Flange 3" ASA 150 PSI				Data nr./Comp No.	Blad/Sheet
				T361D1101	1 / 1
				Drawing No.	Rev.
				T361D1101-1	

NO.	Revision comprises	Date	Sign.	Appr by
-----	--------------------	------	-------	---------